

DPG10002-01, DPG10003-01, DPG10004-01 Microstep Driver Pack

User's Guide



A N A H E I M A U T O M A T I O N

910 East Orangefair Lane, Anaheim, CA 92801
e-mail: info@anaheimautomation.com

(714) 992-6990 fax: (714) 992-0471
website: www.anaheimautomation.com

DPG10002-01, DPG10003-01, DPG10004-01 Microstep Driver Pack Features

- Integrated MBC10641, Power Supply, and Cooling Fan
- 90-265 VAC Input
- Output Current 10.0 Amps Peak
- 200 to 12,800 steps/rev (1,2,5,8,10,16,32 and 64 selectable step operations)
- Short Circuit Protection
- Motor Miss-Wire Detection
- No minimum Inductance
- Optical Isolation
- Motor ON/OFF Input

Introduction

The MBC10641 Microstep Driver has an output current capability of 1.5 Amps minimum to 10.0 Amps maximum (Peak Rating). The MBC10641 driver operates with either a transformer, whose input can be wired from 90-265 VAC or a DC voltage of 30-85 Volts. The inputs are optically isolated with a minimum sourcing of 7.0 mA per input (+5VDC minimum to +24VDC maximum). The clock input is set to receive either positive or negative edge clocks with a maximum frequency of 400KHz. The MBC10641 driver offers direction control and motor current ON/OFF capabilities. The Reduce Current Enabled automatically reduces motor current to 70% of set value after the last step is made (1sec delay). The driver has built-in features to indicate power on (Green LED), Clocks being received (Yellow LED) and fault conditions (Red LED).

With the MBC10641, various step resolutions can be implemented by the onboard dip switch. These divisions range from 200 steps per revolution to 12,800 steps per revolution. The bipolar drive configuration handles 4, 6 and 8 lead motors. Protection devices have been added to this driver for *Phase to Phase Short-Circuit*, *Motor Mis-Wire*, *Over-Temperature* and *Over-Voltage* conditions.

Pin Descriptions

The inputs on the MBC10641 are optically isolated with the anode (+) and cathode (-) both brought out to the user. With no current going through the opto-diode, the input is considered high. To enable the input a minimum of 7.0 mA needs to be sourced or sunk through the opto-diode. This is done simply by placing a voltage of +5 to +24 VDC across the two inputs of the opto-diode. If sourcing current into the inputs, then all three cathodes (-) should be tied together and grounded as shown in Figure 4. If sinking current, then all three anodes (+) should be tied together to the +voltage as shown in Figure 3. Provided on the MBC10641 is an external +5VDC out, which can be used to power the inputs for sinking mode only. However if you use this voltage, isolation is not preserved.

TB2: 5 Pin Terminal Description

Pin #	Description
1	Phase A: Phase 1 of the Step Motor
2	Phase \bar{A} : Phase 3 of the Step Motor
3	Phase B: Phase 2 of the Step Motor
4	Phase \bar{B} : Phase 4 of the Step Motor
5	Motor Ground

Table 1: Pin descriptions for terminal block TB2.

TB1: 8 Pin Terminal - All Connections INTERNALLY Wired to 25DB Port

Pin #	Description
1	Step Clock Input Anode (+): A positive going edge on this isolated input advances the motor one increment. The size of the increment is dependent on the Microstep Select Inputs of Switch 1.
2	Step Clock Input Cathode (-)
3	Direction Anode (+): This isolated input is used to change the direction of the motor. Physical direction also depends on the connection of the motor windings.
4	Direction Cathode (-)
5	ON/OFF Anode (+): This isolated input is used to enable and disable the output section of the driver. When HIGH (open) the outputs are enabled. However, this input does not inhibit the step clock.
6	ON/OFF Cathode (-) - Internally ALL Drivers ON/OFF are tied to PIN14 of the 25DB Port.
7	+5 VDC: This non-isolated output can be used to supply up to 50mA of current to the isolated inputs. By doing this, isolation will be disabled.
8	0 VDC: +5 VDC return.

Table 2: Pin descriptions for terminal block TB1.

Power Supply Requirements

The DPA10002-01, DPG10003-01 and DPG10004-01 are all powered by an AC line voltage ranging from 90-265VAC. The following figure shows the various line voltages.

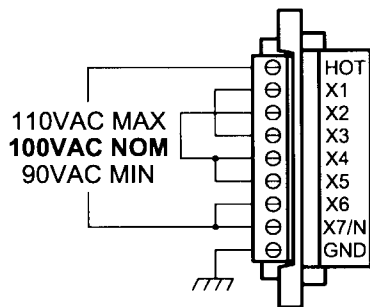

100VAC HOOKUP

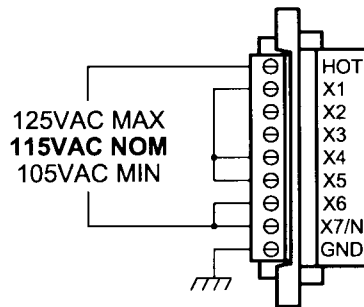

115VAC HOOKUP

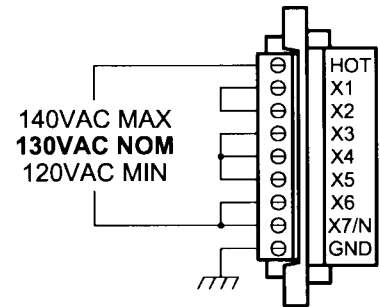

130VAC HOOKUP

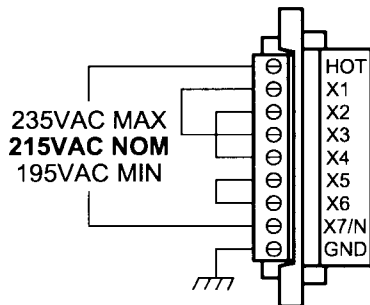

215VAC HOOKUP

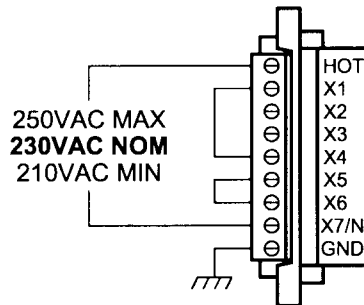

230VAC HOOKUP

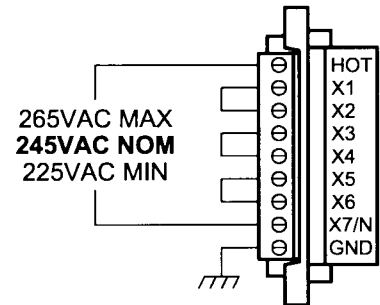

245VAC HOOKUP

Absolute Maximum Ratings

Input Voltage: 90-265 VAC

Output Current: 10.0 AMPS PEAK

Max Plate Temperature: 70° C

Storage Temperature: 0° to +50° C

Input Voltage (For isolated inputs): +5V to +24V at 2.5mA

Electrical Specifications

Item	Min	Typ	Max	Units
Input Voltage	90		265	VAC
Phase Output Current	1.0		7.1	A (RMS)
Phase Output Current	1.5		10.0	A (PEAK)
Clock Frequency	0		400	kHz
Chopping Frequency	20	27	33	kHz
+5VDC	4.8	5	5.2	V
+5VDC	0		50	mA
Operation Temperature	0		70	C

Hook Up Drawings

Hook Up for Current Sinking Inputs

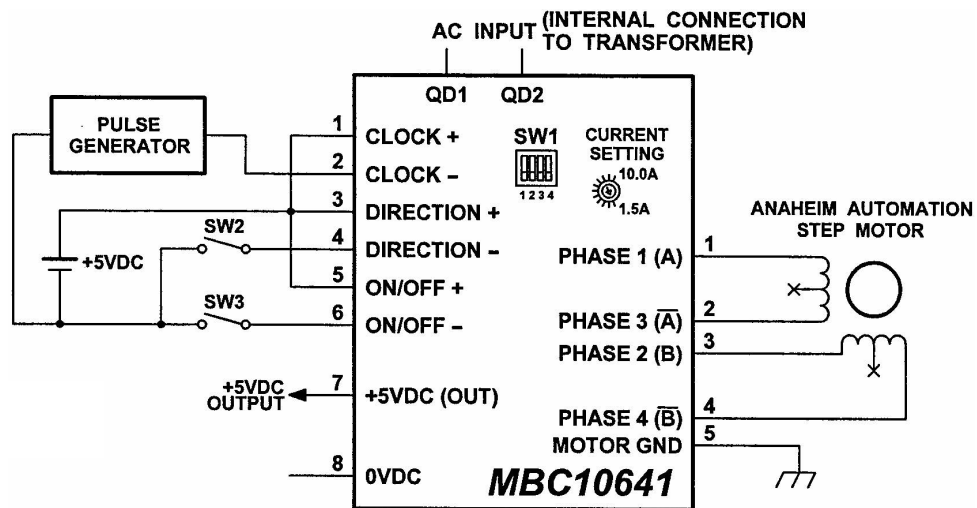

Optional: Non-Isolated +5VDC Output can power the MBC10641 Inputs (but isolation is eliminated).

DB25 PIN Port Connection Description

- | | | | |
|-----|-----------------------|-----|-------------------------------------------|
| 1. | No Connection | 14. | Enable All Windings |
| 2. | No Connection | 15. | No Connection |
| 3. | No Connection | 16. | No Connection |
| 4. | No Connection | 17. | No Connection |
| 5. | No Connection | 18. | No Connection |
| 6. | No Connection | 19. | A Direction Input |
| 7. | No Connection | 20. | Z Direction Input |
| 8. | No Connection | 21. | Y Direction Input |
| 9. | X Direction | 22. | +5VDC Input Required to Power Driver OPTO |
| 10. | A Step (Clock Input) | 23. | +5VDC Input Required to Power Driver OPTO |
| 11. | Z Step (Clock Input) | 24. | No Connection |
| 12. | Y Step (Clock Input) | 25. | No Connection |
| 13. | X Step (Clock Input) | | |

Optically Isolated Inputs

The following inputs to the MBC10641 are Optically Isolated.

Item	Pin #
Clock	1 & 2
Direction	3 & 4
On/Off	5 & 6

To enable an input, apply a DC voltage source of +5VDC to +24VDC across the inputs. The Anodes (+) are pins 1,3,and 5 and the Cathodes (-) are pins 2, 4, and 6.

Motor Selection

The MBC10641 is a Bipolar Microstep Driver that is compatible with both Bipolar and Unipolar Motor Configurations, (i.e. 8 and 4 lead motors, and 6 lead center tapped motors).

Step motors with low current ratings and high inductance will perform better at low speeds, providing higher low-end torque. Motors with high current ratings and low inductance will perform better at higher speeds, providing more high-end torque.

Since the MBC10641 is a constant current source, it is not necessary to use a motor that is rated at the same voltage as the supply voltage. What is important is that the MBC08161 is set to the appropriate current level based on the motor being used. Higher voltages will cause the current to flow faster through the motor coils. This in turn means higher step rates can be achieved. *Care should be taken not to exceed the maximum voltage of the driver.*

Anaheim Automation offers a comprehensive line of step motors in 17, 23, 34 and 42 frame sizes. Contact the factory to verify motor/ drive compatibility.

Microstep Selection (SW1 Settings)

Switches 2, 3 and 4, of the DIP switch select the number of microsteps per step. Table 7 shows the standard resolution values along with the associated positions for the select switches. The standard waveforms are sinusoidal.

Resolution	Steps/Rev	Select 1	Select 2	Select 3	Select 4	Auto Reduce Current
1	200	OFF	ON	ON	ON	Disabled
2	400	OFF	ON	ON	OFF	Disabled
5	1000	OFF	ON	OFF	ON	Disabled
8	1600	OFF	ON	OFF	OFF	Disabled
10	2000	OFF	OFF	ON	ON	Disabled
16	3200	OFF	OFF	ON	OFF	Disabled
32	6400	OFF	OFF	OFF	ON	Disabled
64	12800	OFF	OFF	OFF	OFF	Disabled
1	200	ON	ON	ON	ON	Enabled
2	400	ON	ON	ON	OFF	Enabled
5	1000	ON	ON	OFF	ON	Enabled
8	1600	ON	ON	OFF	OFF	Enabled
10	2000	ON	OFF	ON	ON	Enabled
16	3200	ON	OFF	ON	OFF	Enabled
32	6400	ON	OFF	OFF	ON	Enabled
64	12800	ON	OFF	OFF	OFF	Enabled

Table 6: Microstep Selection on Switch 1.

Setting the Output Current

The output current on the MBC10641 is set by an onboard potentiometer. This potentiometer determines the per phase peak output current of the driver. The relationship between the output current and the potentiometer value is as follows:

Peak Current	Potentiometer Setting	Peak Current	Potentiometer Setting
1.5A	0%	7.0A	60%
2.3A	10%	7.9A	70%
3.1A	20%	8.7A	80%
4.0A	30%	9.6A	90%
5.0A	40%	10A	100%
6.0A	50%	--	--

Table 7: Potentiometer values with respect to the output current

Refer to Table 5 for specific motor current settings.

Step Motor Selection Guide

Motor Example	Motor Current Number Code	Unipolar Rating	Series Peak Rating	Parallel Peak Rating	Series Current Setting	Parallel Current Setting
23D102S	02	1.0A	1.0A	2.0A	----	5%
23L303D-LW8	03	1.5A	1.5A	3.0A	0%	20%
34N104S-LW8	04	2.0A	2.0A	4.0A	5%	30%
23L4005D-LW8	05	2.5A	2.5A	5.0A	10%	40%
34A106B	06	3.0A	3.0A	6.0A	20%	50%
34N207S-LW8	07	3.5A	3.5A	7.0A	25%	60%
34K108S-LW8	08	4.0A	4.0A	8.0A	30%	70%
42N209S-CB	09	4.5A	4.5A	9.0A	35%	85%
23L310S-LW8	10	5.0A	5.0A	10.0A	40%	100%
34D311D	11	5.5A	5.5A	11.0A	45%	100%
42K112S-CB	12	6.0A	6.0A	12.0A	50%	100%
34D213S	13	6.5A	6.5A	13.0A	55%	100%
34N314S-LW8	14	7.0A	7.0A	14.0A	60%	100%
42N115D-CB	15	7.5A	7.5A	15.0A	65%	----
34K416S-LW8	16	8.0A	8.0A	16.0A	70%	----
42D119D	19	9.5A	9.5A	19.0A	90%	----
42N322S-CB	22	11.0A	11.0A	22.0A	100%	----
42D225S	25	12.5A	12.5A	25.0A	100%	----

TABLE 5 - Table Selection for Anaheim Automation Motor Current Settings.

**Anaheim Automation offers motor cable, making hook-ups quick and easy!
Contact the factory or visit our website for more motor and cable offerings.**

Reducing Output Current

Reducing the output current is accomplished by setting switch 1 of the DIP switch to the ON position and occurs approximately 1 second after the last positive going edge of the step clock input. The amount of current per phase in the reduction mode is approximately 70% of the set current. When the current reduction circuit is activated, the current reduction resistor is paralleled with the current adjustment potentiometer. This lowers the total resistance value, and thus lowers the per Phase output current.

Determining Output Current

The output current for the motor used when microstepping is determined differently from that of a full/half step unipolar driver. In the MBC08161, a sine/cosine output function is used in rotating the motor. The output current for a given motor is determined by the motors current rating and the wiring configuration of the motor. There is a current adjustment potentiometer used to set the output current of the MBC10641. This sets the peak output current of the sine/cosine waves. The specified motor current (which is the unipolar value) is multiplied by a factor of 1.0, 1.4, or 2.0 depending on the motor configuration (series, half-coil, or parallel).

Step Motor Configurations

Step motors can be configured as 4, 6, or 8 leads. Each configuration requires different currents. Refer to the lead configurations and the procedures to determine their output current.

WARNING! Step motors will run hot even when configured correctly. Damage may occur to the motor if a higher than specified current is used. Most specified motor currents are maximum values. Care should be taken to not exceed these ratings.

6 Lead Motors

When configuring a 6 lead motor in a **half-coil configuration** (connected from one end of the coil to the center tap), multiply the specified per Phase (or unipolar) current rating by 1.4 to determine the current setting potentiometer value. This configuration will provide more torque at higher speeds when compared to the series configuration.

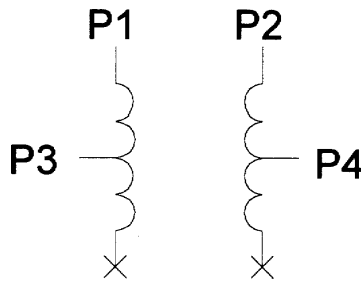

When configuring the motor in a **series configuration** (connected from end to end with the center tap floating) use the specified per Phase (or unipolar) current rating to determine the current setting potentiometer value.

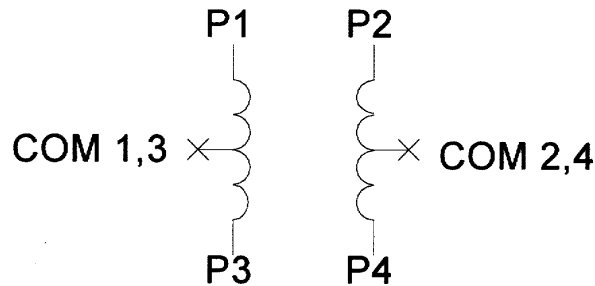

4 Lead Motors

Multiply the specified **series** motor current by 1.4 to determine the current adjustment potentiometer value. Four Lead Motors are usually rated with their appropriate series current, as opposed to the *Phase Current*, which is the rating for 6 and 8 lead motors.

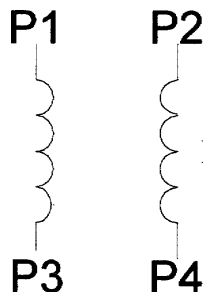

8 Lead Motors

Series Connection: When configuring the motor windings in series, use the per Phase (or unipolar) current rating to determine the current setting potentiometer value.

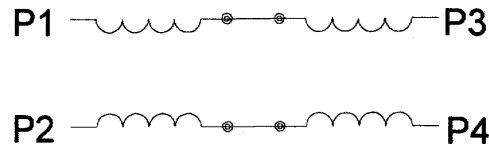

Parallel Connection: When configuring the motor windings in parallel, multiply the per Phase (or unipolar) current rating by 2.0 to determine the current setting potentiometer value.

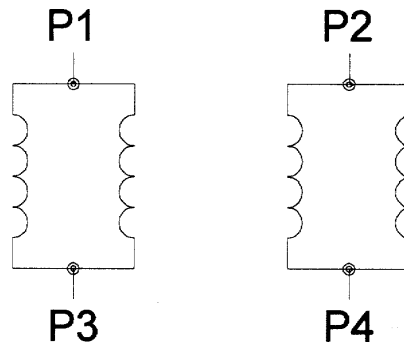

NOTE: After the current has been determined, according to the motor connections above, use Table 3 to choose the proper setting for the current setting potentiometer.

Connecting the Step Motor

Phase 1 and 3 of the Step Motor is connected between pins 1 and 2 on the motor connector (TB2). Phase 2 and 4 of the Step Motor is connected between pins 3 and 4 on the motor connector (TB2). The motors case can be grounded to pin 5 on the motor connector (TB2). Refer to the figures for the hook-up drawings for TYPICAL APPLICATION HOOK-UPS.

NOTE: The physical direction of the motor with respect to the direction input will depend on the connection of the motor windings. To reverse the direction of the motor with respect to the direction input, switch the wires on Phase 1 and Phase 3.

WARNING: Do not connect or disconnect motor wires while power is applied!

Short-Circuit, Mis-Wire, and Over-Current Conditions

If it is found that there is a condition that causes an over current in the driver phase transistors, the Red LED will turn on solid and power will be shut off to the motor. To reset the drive turn power off, check wiring, and turn power back on.

Over-Temperature and Over-Voltage Conditions

If it is found that there is an over temperature on the internal heat sink, or an over voltage on the motor bus voltage, the Red LED will blink and power will be shut off to the motor. To reset the drive turn power off, check wiring, and turn power back on.

COPYRIGHT

Copyright 2001 by Anaheim Automation. All rights reserved. No part of this publication may be reproduced, transmitted, transcribed, stored in a retrieval system, or translated into any language, in any form or by any means, electronic, mechanical, magnetic, optical, chemical, manual, or otherwise, without the prior written permission of Anaheim Automation, 910 E. Orangefair Lane, Anaheim, CA 92801.

DISCLAIMER

Though every effort has been made to supply complete and accurate information in this manual, the contents are subject to change without notice or obligation to inform the buyer. **In no event will Anaheim Automation be liable for direct, indirect, special, incidental, or consequential damages arising out of the use or inability to use the product or documentation.**

Anaheim Automation's general policy does not recommend the use of its' products in life support applications wherein a failure or malfunction of the product may directly threaten life or injury. Per Anaheim Automation's Terms and Conditions, the user of Anaheim Automation products in life support applications assumes all risks of such use and indemnifies Anaheim Automation against all damages.

LIMITED WARRANTY

All Anaheim Automation products are warranted against defects in workmanship, materials and construction, when used under Normal Operating Conditions and when used in accordance with specifications. This warranty shall be in effect for a period of twelve months from the date of purchase or eighteen months from the date of manufacture, whichever comes first. **Warranty provisions may be voided if products are subjected to physical modifications, damage, abuse, or misuse.**

Anaheim Automation will repair or replace at its' option, any product which has been found to be defective and is within the warranty period, provided that the item is shipped freight prepaid, with previous authorization (RMA#) to Anaheim Automation's plant in Anaheim, California.

TECHNICAL SUPPORT

If you should require technical support or if you have problems using any of the equipment covered by this manual, please read the manual completely to see if it will answer the questions you have. Be sure to refer to the TROUBLESHOOTING section of this manual. If you need assistance beyond what this manual can provide, contact your Local Distributor where you purchased the unit, or contact the factory direct.

Torque Speed Curves

MBC10641 with 23L104 and 23L106 at 80V

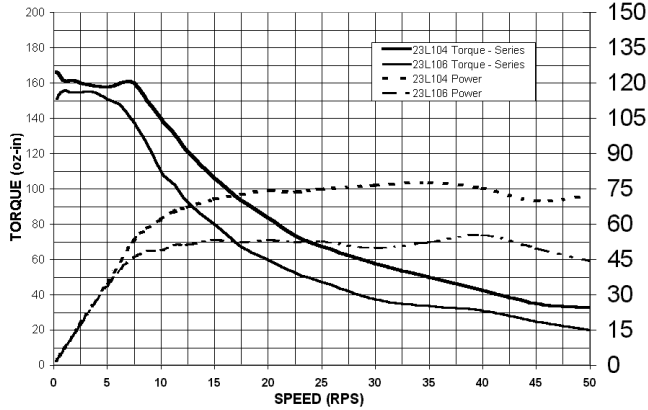

MBC10641 with 23L108 and 23L204 at 80V

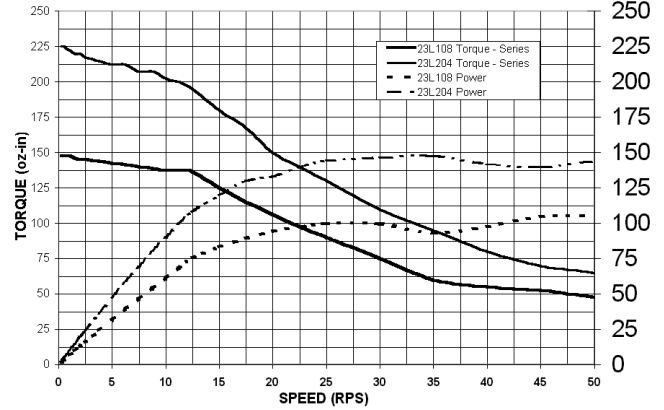

MBC10641 with 23L210 and 23L310 at 80V

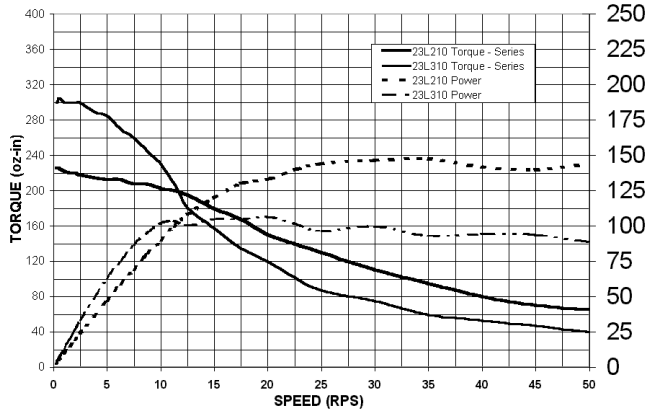

MBC10641 with 23L306 and 34N112 at 80V

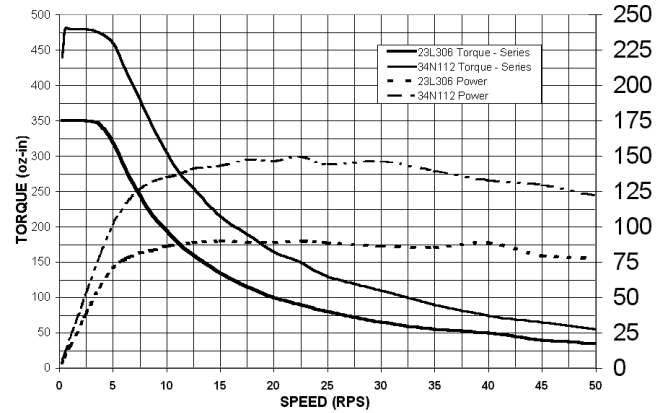

MBC10641 with 34N104 and 34N108 at 80V

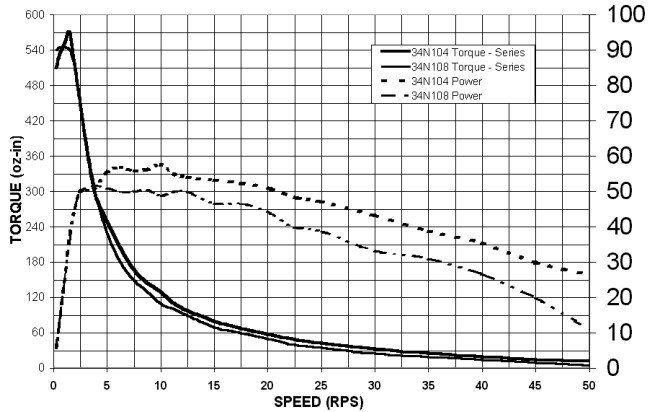

MBC10641 with 34D207 and 34D209 at 80V

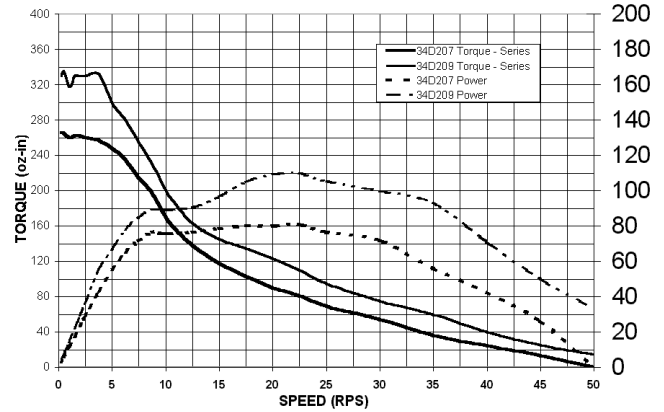

ANAHEIM AUTOMATION